



# ***Jam In A Box***

Portable Jam Equipment: *Tested & Proven*

Prepared by:	Dated Last Edited:
Allan Barnard	April 9 <sup>th</sup> , 2005
for <a href="http://www.ParkJammer.com">www.ParkJammer.com</a>	



# Jam In A Box

## Index

JAM-IN-A-BOX HISTORY .....	3
REQUIREMENTS .....	4
PACKING TYPE "A": SMALL TRAVEL GUITAR & AMP.....	5
PACKING TYPE "B": FULL-LENGTH THIN-BODY GUITAR & AMP.....	6
SUPPORTING INFORMATION .....	7
SOURCES .....	7
AIRLINES AND INSTRUMENTS.....	7
PLANNED ITEMS.....	8
REQUIREMENTS.....	8
COMPONENTS .....	9
SELECTED ITEMS.....	10
CONSIDERED ITEMS.....	13
GUITARS .....	13
AMPLIFIERS.....	16
MISCELLANEOUS.....	18
CONTACT INFORMATION .....	19



# *Jam In A Box*

## Jam-In-A-Box History

As a computer professional with a penchant for playing music, I have a need for travel-worthy gear and a penchant for technology. Yet, as a farm boy, I have an appreciation for the simple, strong, and practical. Assembled here is a combination of the simple and tough with the technologically advanced allowing music experiences just about anywhere.

It was later in life (about 30) that I finally managed to achieve the garage band experience that I had long and longingly longed for over the years. With a strong grasp of music fundamentals, an ability to approach other musicians, and a dozen tunes memorized, I was ready to sit on the lawn in Central Park and throw a few songs into the ether. So began [www.ParkJammer.com](http://www.ParkJammer.com).

At ParkJammer our goals have been to put music and performance quality ahead of ego, include songs interesting to a wide spectrum of listeners and musicians, and just soak up the joy of playing. We did this on wildly amazing sunny afternoons and evenings in Central Park, complete with red wine, the glow of 19<sup>th</sup> century street lights, fireflies, and endless numbers of listeners, singers, and musicians.

In the process we learned how to:

- Add just enough power to an otherwise acoustic presentation such that all parts could be heard at a pleasant volume to a reasonable area (50 to 100 feet in front of us).
- Keep our powered components discreet so as not to run afoul of local ordinances
- Purchase tough, long-lasting, travel-safe and comfortable gear that allowed us to focus on the music and not on technical annoyances
- Design music transcriptions that allow for rapid re-keying to meet the needs of a singer and which are generally on a single page (easier to tack down in windy conditions without having to flip pages mid-song).

In addition, my consultancy-related travel pitted me and my equipment against airline regulations and baggage handlers. The net result is a set of travel and gig proven equipment and methods that will let an ordinary performer manage gigs almost anywhere with acoustic power and a lot of control.

The ultimate “**Jam In A Box**” needs to transport quality equipment via airline in a safe and affordable manner. With this requirement met, transporting the same equipment via rail, bus, car, subway, or walking on the sidewalk are easily met. The transport equipment needs to have wheels, pro-quality backpack straps, padding, and the ability to locked and tethered. My plan was to design this into a custom luggage and gear set for commercial sale. This has been delayed until requirements have settled down (post 9-11 security and airline belt-tightening having created changing conditions).

If you render it all down, **Jam In A Box** needs to be:

- ♪ **Tough**
- ♪ **Highly portable**
- ♪ **Compliant with air-travel regulations**



# Jam In A Box

## Requirements

Eventually I will complete the construction of a formal “**Jam In A Box**” package that includes travel and performance proven luggage and equipment. Until then I’ve achieved the same thing with a combination of commercial products. I take this equipment everywhere I go for both personal and business travel. They manage to make **every flight** on every airline despite anecdotal evidence from some that you can’t take full sized guitars as carry-on.

Note that depending on the situation I occasionally take a full-sized semi-acoustic Godin guitar or a ¾ sized Ibanez DayTripper semi-acoustic. Surprisingly I always manage to get the guitar, the amplifier, and my laptop on board even the smallest Canadair RJ-100 jet as carry-on. Really.

The same setup makes it easy to haul your gear in a safe and efficient manner to the beach or to the park. I’ve even done fully powered pub gigs in North America and abroad with just the stuff on my back. While an available power socket never hurts, all of this gear is 100% battery powered so you’re never restricted by the limitations of the gig site.







The setup requires two bags; one that can safely go as baggage and another that can go as carry-on. And how you pack them varies depending on whether you have a full size guitar or a travel guitar.



- 1) Tough ballistic nylon **gig bag** (holds the guitar and the amp)
- 2) A second **backpack**-rollaway bag for electronics, lyrics, and clothes
- 3) An **Ibanez Daytripper Guitar** (standard tuning but smaller body and neck) or a **Godin Multiac Duet guitar**
- 4) A **Fender Amp Can** (two inputs, distortion, good bottom end, long battery life)
- 5) Combination **music/lyric books**
- 6) **Guitar tool kit** (tuner, strings, string winder/cutter with rounded tip [airline requirement], spare batteries)
- 7) A **Boss reverb unit** used primarily to add some character to the vocal input (not the guitar)
- 8) Samson **Airline wireless** guitar cord and wireless microphone equipment to eliminate (or hide!) cords
- 9) A **spare headset microphone** from Radio Shack (cheap, tough) and a **spare handheld microphone** with cord and XLR-to-¼” converter.
- 10) **Clothes** and related supplies
- 11) Generally I also have a separate laptop in a laptop bag

**Warning:** The amp must travel as carry-on because the cone will suffer damage in baggage no matter how well you pack it. This is due to security inspections that inevitably highlight the amp, force inspection, and result in a poor re-pack. I’ve had two amps killed this way despite careful packing and notes left for inspection personnel.

## Packing Type “A”: Small travel guitar & amp

This two-bag packing method keeps the guitar and the amplifier in the same gig bag leaving your “handbag” allowance free for an additional laptop or other bag. You will have to stop at security and have everything checked out so leave enough time to re-pack after the security check. All easily packed and protected stuff goes in backpack-rollaway that will go through standard baggage.

 <b>Bag #1 of 2</b>			
Description	Picture	Description	Picture
<b>Heavy Duty Gig Bag</b> <ul style="list-style-type: none"> <li>Tough, long lasting, comfortable</li> <li>Heavy duty padded backpack straps</li> </ul>		<b>Ibanez DayTripper Travel Guitar</b> <ul style="list-style-type: none"> <li>Acoustic/Electric guitar</li> <li>Sounds good plugged in or acoustic</li> <li>Minor feedback issues</li> <li>Have prepared a bubble-wrap liner to protect the guitar inside the case</li> </ul>	
<b>Fender Amp Can</b> <ul style="list-style-type: none"> <li>9" x 8" x 7"</li> <li>great bass for a portable amp</li> <li>a vocal input and a guitar input</li> <li>long life (8+ hours initially)</li> <li>Wrapped in a bit of bubble wrap to protect guitar</li> <li><b>Warning:</b> you absolutely will have to stop and show this at airline security</li> </ul>		<b>Samson Wireless AH1 / SeriesOne Microphone</b> <ul style="list-style-type: none"> <li>wireless headset microphone</li> <li>battery both sides</li> <li>stored in outside pocket of gig bag in a cheap plastic case from an office supply store</li> </ul>	
<b>Boss RV-5 Reverb Unit</b> <ul style="list-style-type: none"> <li>Used primarily for vocal enhancement despite it being a guitar pedal</li> <li>stored in outside pocket of gig bag in a cheap plastic case from an office supply store</li> </ul>		<ul style="list-style-type: none"> <li><b>Warning:</b> leave all spare strings and other supplies in a separate case bound for baggage, especially on international flights. Loose strings are apparently considered dangerous in these post 9-11 paranoia-driven times.</li> </ul>	

 <b>Bag #1 of 2</b>			
Description	Picture	Description	Picture
<b>Heavy Duty Wheeled Backpack</b> <ul style="list-style-type: none"> <li>Eagle Creek Switchback Modular 22</li> <li>Separate daypack</li> <li>Tough &amp; hidden backpack straps</li> <li>Tough wheels and handle</li> </ul>		<b>Supplies</b> <ul style="list-style-type: none"> <li>Clothes</li> <li>Toiletries</li> <li>Guitar tool kit (strings, batteries, etc)</li> <li>Spare microphones</li> <li>Spare cables</li> <li>Guitar stand and/or small mic stand</li> <li>Electronics packed at the center of the clothes</li> <li>Lyric books</li> </ul>	<p>Not Available</p>







## Packing Type “B”: Full-length thin-body guitar & amp



This two-bag method requires one extra bag. Just for the carry-on part of your trip, you need a small nylon bag. If it looks like a laptop bag you’ll have fewer hassles. No matter how small, if it looks like an extra “piece of luggage” rather than a “handbag or laptop”, you can get a boneheaded airline person creating trouble for you. If it says “laptop” on the side the neural-challenged staff will not question it.

Things still need to appear as two bags (one luggage, one “small personal item”). So just before security, you put your laptop in the gig bag behind the thin-body semi-acoustic. Then you put the amp into the laptop bag. No worries.

Note that when you arrive at your destination, you will need to move the amplifier to the backpack-rollaway and move some electronics and/or clothes to the gig bag for day-to-day walking or vehicular travel.

**Warning:** The amp must travel as carry-on because the cone will suffer damage in baggage no matter how well you pack it. This is due to security inspections that inevitably highlight the amp, force inspection, and result in a poor re-pack. I’ve had two amps killed this way despite careful packing and notes left for inspection personnel.

 <b>Bag #1 of 2</b>			
Description	Picture	Description	Picture
<b>Heavy Duty Gig Bag</b> <ul style="list-style-type: none"> <li>Tough, long lasting, comfortable</li> <li>Heavy duty padded backpack straps</li> </ul>		<b>20) Godin Multiac Semi-Acoustic</b> <ul style="list-style-type: none"> <li>Acoustic/Electric guitar</li> <li>Wide neck</li> <li>Stunning sound when plugged in</li> <li>Thin body... lets some clothes and a laptop to fit in the gig bag under the guitar</li> </ul>	
<b>Fender Amp Can</b> <ul style="list-style-type: none"> <li>9" x 8" x 7"</li> <li>great bass for a portable amp</li> <li>a vocal input and a guitar input</li> <li>long life (8+ hours initially)</li> <li>Wrapped in a bit of bubble wrap to protect guitar</li> <li><b>Warning:</b> you absolutely will have to stop and show this at airline security</li> </ul>		<b>Samson Wireless AH1 / SeriesOne Microphone</b> <ul style="list-style-type: none"> <li>wireless headset microphone</li> <li>battery both sides</li> <li>stored in outside pocket of gig bag in a cheap plastic case from an office supply store</li> </ul>	
<b>Boss RV-5 Reverb Unit</b> <ul style="list-style-type: none"> <li>Used primarily for vocal enhancement despite it being a guitar pedal</li> <li>stored in outside pocket of gig bag in a cheap plastic case from an office supply store</li> </ul>		<ul style="list-style-type: none"> <li><b>Warning:</b> leave all spare strings and other supplies in a separate case bound for baggage, especially on international flights. Loose strings are apparently considered dangerous in these post 9-11 paranoia-driven times.</li> </ul>	

 <b>Bag #1 of 2</b>			
Description	Picture	Description	Picture
<b>Heavy Duty Wheeled Backpack</b> <ul style="list-style-type: none"> <li>Eagle Creek Switchback Modular 22</li> <li>Separate daypack</li> <li>Tough &amp; hidden backpack straps</li> <li>Tough wheels and handle</li> </ul>		<b>Supplies</b> <ul style="list-style-type: none"> <li>Clothes</li> <li>Toiletries</li> <li>Guitar tool kit (strings, batteries, etc)</li> <li>Spare microphones</li> <li>Spare cables</li> <li>Guitar stand and/or small mic stand</li> <li>Electronics packed at the center of the clothes</li> <li><b>Will hold the amp once you're passed the air travel portion of your trip</b></li> </ul>	<p style="text-align: center;">Not Available</p>



# Jam In A Box

## Supporting Information

### Sources

Before beginning, note that the absolute best place to get electronics (including most sound, photo, and camera) gear is **B&H Photo Video (BH)** in Manhattan. It will **always** be the **best price** for **new equipment**. You might find cheaper stuff on eBay but it's often slightly used, gray market, or otherwise questionable. B&H has an excellent online presence and a GREAT store in Manhattan. They'll ship anywhere, often without charge.

Links	Links
<ul style="list-style-type: none"><li>• <a href="http://www.BHphotovideo.com">www.BHphotovideo.com</a></li><li>• <a href="http://www.MusiciansFriend.com">www.MusiciansFriend.com</a></li><li>• <a href="http://www.SamAsh.com">www.SamAsh.com</a></li><li>• <a href="http://www.GuitarWorld.com">www.GuitarWorld.com</a></li><li>• <a href="http://www.WholeNote.com">www.WholeNote.com</a></li><li>• <a href="http://www.CaseTechnology.com">www.CaseTechnology.com</a></li><li>• <a href="http://www.FineCases.com">www.FineCases.com</a></li></ul>	<ul style="list-style-type: none"><li>• <a href="http://www.LuteHole.com">www.LuteHole.com</a></li><li>• <a href="http://www.Bananas.com">www.Bananas.com</a></li><li>• <a href="http://www.SameDayMusic.com">www.SameDayMusic.com</a></li><li>• <a href="http://www.SamsonTech.com">www.SamsonTech.com</a></li><li>• <a href="http://www.GodinGuitars.com">www.GodinGuitars.com</a></li><li>• <a href="http://www.Ibanez.com">www.Ibanez.com</a></li></ul>

### Airlines and Instruments

I fly all the time. With my guitars (small and large). And... I carry the guitar and amp on board. Really. Every airline. There's an art form to it. And a lot of preparation. But you end up with quality equipment everywhere you find yourself. It's worth it!

Before you ask... the answer is "Yes, everything from a Canadair RJ100 or a small Embraer all the way to 747s". I'll post pictures of the equipment in each airplane overhead when I have time. Later I'll add detail about FAA policies, individual airline policies, and packing for in-cabin musical instrument carriage. Stay tune. For now however, check out these links:



Links
<ul style="list-style-type: none"><li>• <a href="http://www.thetravelinsider.info/travelaccessories/airlinecarryonluggageallowances.htm">www.thetravelinsider.info/travelaccessories/airlinecarryonluggageallowances.htm</a></li><li>• <a href="http://www.delta.com/travel/plan/baggage_info/special_baggage/musical_instruments/index.jsp">www.delta.com/travel/plan/baggage_info/special_baggage/musical_instruments/index.jsp</a></li><li>• <a href="http://www.finecases.com/about/airline-travel.html">www.finecases.com/about/airline-travel.html</a></li></ul>



# Jam In A Box



## Planned Items

### Requirements





 <b>Jam In A Box Requirements (custom built setup)</b>		
Item	Qualities	Contained Items
	<ul style="list-style-type: none"> <li>• hard shell for airline travel</li> <li>• wheels and a drag handle</li> <li>• center divider               <ul style="list-style-type: none"> <li>• upper for clothes or miscellaneous material</li> <li>• lower for guitar and amplifier</li> <li>• padded divider in between</li> </ul> </li> <li>• anchor for cable lock</li> <li>• recessed latches if possible</li> <li>• lockable latch</li> <li>• either custom padding for the items held within, or slightly movable padding</li> <li>• ballistic nylon cover with shoulder and possibly waist straps               <ul style="list-style-type: none"> <li>• aluminum backpack frame within nylon covering</li> <li>• padded shoulder straps</li> <li>• outside zipper pockets</li> <li>• wheels and drag handle to be on opposite side from shoulder straps</li> <li>• holes in covering to accommodate wheels and drag handle</li> <li>• clips for-over-the shoulder strap for non-backpack oriented handling and carrying</li> </ul> </li> <li>• as light as possible within the above requirements</li> <li>• fits in taxi trunk</li> </ul>	<ul style="list-style-type: none"> <li>• ¾ size acoustic electric guitar (34" long)</li> <li>• battery powered amplifier</li> <li>• wireless guitar pickup</li> <li>• wireless vocal headset microphone</li> <li>• jingle stick (straight tambourine)</li> <li>• shaker egg</li> <li>• standard guitar support kit               <ul style="list-style-type: none"> <li>• strings</li> <li>• tuner</li> <li>• guitar cord</li> <li>• standard headset mic</li> <li>• standard handheld mic</li> <li>• string winder</li> <li>• string cutter</li> <li>• guitar string lubrication</li> <li>• capo</li> </ul> </li> <li>• security cable with combination lock</li> <li>• lyric book</li> <li>• tough but portable music stand</li> <li>• chair (s)</li> <li>• folded guitar backpack for light local travel</li> <li>• battery powered light for night playing</li> <li>• flashlight</li> <li>• batteries</li> <li>• sunscreen and bug repellent</li> <li>• leatherman multi-tool</li> <li>• clothes area</li> <li>• miscellaneous tools and cables area</li> </ul>
	<b>Notes</b> <ul style="list-style-type: none"> <li>• The expectation is that one can travel in North America with a separate clothes suitcase and this music ensemble.</li> <li>• When traveling to Europe, items will be removed from the music ensemble and a small amount of clothes will be added and only the music ensemble case will be taken.</li> </ul>	

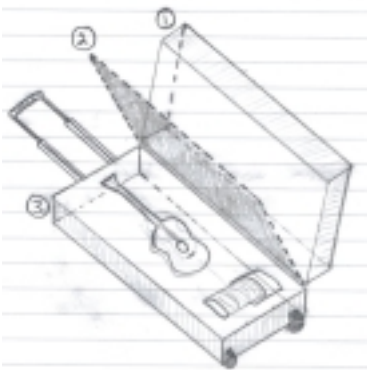
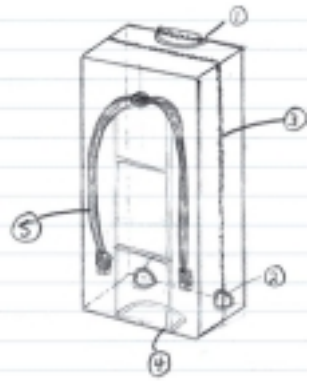











## Components

 <b>Planned Items</b>		
Price	Description	Picture
\$420	<p><b>Ultralite Tote (hardshell, wheels, handle)</b></p> <p><b>Note:</b> This represents a plan to be built... at present I'm using a heavy duty ballistic nylon gig bag to hold a guitar and amp with a separate small and tough rollaway suitcase with heavy duty backpack straps build in. The biggest reason is that carrying the amp on board prevents damage that is often done in baggage to the speaker cone even when packed incredibly well.</p> <ul style="list-style-type: none"> <li>• <a href="http://www.CaseTechnology.com">www.CaseTechnology.com</a> Att: Bob Albano 26 Hayward Street Ipswich, MA 01938 work) 978-356-6011 cell) 978-502-9065 email) <a href="mailto:Bob@CaseTechnology.com">Bob@CaseTechnology.com</a></li> <li>• Dimensions: length= 52", width = 30", depth = 24"</li> <li>• upper part of case for chair, stand, lyrics, and/or clothes</li> <li>• padded divider</li> <li>• lower part of case for small travel guitar, fender amp can, various tools, and miscellaneous storage.</li> <li>• The entire case to be surrounded by foam padding.</li> </ul>	 
\$200	<p><b>Custom Nylon Cover</b></p> <p>Again, this is a planned cover for a planned case. I'll eventually have it done by Case Technology.</p> <ol style="list-style-type: none"> <li>1) Hole for handle</li> <li>2) Seriously tough zipper</li> <li>3) Holes for wheels</li> <li>4) Aluminum frame in "L" shape around back and bottom of pack</li> <li>5) Padded backpack straps, possibly a waist strap also</li> <li>6) Possible support straps wrapping around body to aid zipper.</li> <li>7) Orientation is such that the handle and wheels are away from the backpack straps</li> </ol>	

## Selected Items

 <b>Selected Items</b>		
Price	Description	Picture
\$150	<p><b>10) Heavy Duty Gig Bag</b></p> <ul style="list-style-type: none"> <li>• <a href="http://www.toughtraveler.com/guitar_bags.asp">http://www.toughtraveler.com/guitar_bags.asp</a></li> <li>• I've had this bag for almost a decade.</li> <li>• It has hauled a LOT of stuff... and a LOT of HEAVY stuff</li> <li>• Two shoulder straps... comfortable with two, comfortable with one</li> <li>• Will take a Godin semi-acoustic and a bunch of clothes</li> <li>• Will take a Daytripper and an Amp Can (heavy)</li> <li>• With creative packing, will carry music, electronics, and the guitar and the amp</li> <li>• This sucker is damn near indestructible!!!</li> </ul>	
\$250	<p><b>10) Heavy Duty Wheeled Backpack</b></p> <ul style="list-style-type: none"> <li>• <a href="http://www.EagleCreek.com">www.EagleCreek.com</a></li> <li>• Model: Switchback Modular 22 <ul style="list-style-type: none"> <li>• Item #20115</li> <li>• capacity 3600 cubic inches, 59 liters (total)</li> <li>• dimensions: 14"x22"x9"</li> <li>• weight: 9lbs, 4oz (4.2 kg)</li> <li>• fabric: 500/420D double cord</li> </ul> </li> <li>• Has heavy duty (but hidden) backpack straps</li> <li>• Still rolls like a rollaway</li> <li>• Separate day pack</li> <li>• Will carry the Fender Amp Can plus other stuff</li> <li>• With just these two bags (the Tough Traveler gig bag and this) I've been able to carry enough gear and clothes to travel for a month... with a Godin guitar in the case, an amp in the backpack, and clothes spread between the two.</li> <li>• This is a tough bag!</li> </ul>	
\$250	<p><b>20) Ibanez DayTripper Travel Guitar</b></p> <ul style="list-style-type: none"> <li>• <a href="http://www.ibanez.com/guitars/guitar.asp?model=DTMETBL">www.ibanez.com/guitars/guitar.asp?model=DTMETBL</a></li> <li>• Acoustic/Electric travel guitar</li> <li>• Sounds good plugged in or acoustic</li> <li>• Has some minor feedback problems if held too close to the amp... needs a sound hole cover but it has a non-standard sound hole</li> <li>• 35" total length</li> <li>• Standard tuning,</li> <li>• Full-sized tone without the bulk</li> <li>• Mini-dreadnought body has a spruce top</li> <li>• Rosewood fretboard and bridge</li> <li>• Mahogany neck, back, and sides</li> <li>• Shimmering high-gloss finish</li> <li>• 12.5"W x 18"L x 3.5"D.</li> </ul>	





 <b>Selected Items</b>		
Price	Description	Picture
\$600	<b>20) Godin Multiac Semi-Acoustic</b> <ul style="list-style-type: none"> <li>• <a href="http://www.GodinGuitars.com">www.GodinGuitars.com</a></li> <li>• Acoustic/Electric guitar</li> <li>• Wide neck, good for strumming or picking</li> <li>• Quiet (no sound hole) when played acoustically</li> <li>• Amazing acoustic sound when powered</li> <li>• Real microphone along with a bridge pickup, controlled by a blender</li> <li>• Bass, midrange, and treble mix controls</li> <li>• Feedback prevention controls</li> <li>• On-board pre-amp</li> <li>• ¼" jack and an XLR jack</li> </ul>	
\$180	<b>30) Fender Amp Can</b> <ul style="list-style-type: none"> <li>• <a href="http://www.fender.com">www.fender.com</a></li> <li>• 9" x 8" x 7"</li> <li>• great low end for a portable amp</li> <li>• a vocal input and a guitar input</li> <li>• guitar input has slightly more bass</li> <li>• has a distortion button in the guitar area</li> <li>• on a full charge it has played at normal levels for as long as 14 hours</li> <li>• on average, after a year or two of use, it will go for four or more hours without any trouble</li> </ul>	
\$370	<b>40) Samson Wireless AH1</b> <ul style="list-style-type: none"> <li>• wireless headset microphone, battery both sides</li> <li>• <a href="http://www.samsontech.com">www.samsontech.com</a></li> <li>• <a href="http://www.wholenote.com">www.wholenote.com</a></li> <li>• <a href="http://www.ProAudioMusic.com">www.ProAudioMusic.com</a></li> <li>• <a href="http://www.bhphotovideo.com">www.bhphotovideo.com</a></li> <li>• get the "Qv" option for "vocal" use... not the "Qe" version for fitness use.</li> <li>• ALVHSU4 Wall/Table Mount UHF Micro Airline Vocal Headset System with AR1 Receiver, AH1 Headset Mount Transmitter and Qv Headset Microphone (Channel U4/803.750 MHz)</li> <li>• I phoned Samson directly and had them pair the AH1 headset with a two-antenna receiver called the "Series One". This raised the cost because it was non-standard. But... the result was a much better transmitter/receiver pair.</li> <li>• The key thing about this setup, regardless of how you do it, is that it's battery powered both on send and receive</li> <li>• It's very sensitive so you can't use it directly alongside the amp. You need to turn the gain down (send and receive) and stand at least 6 or 10 feet away from the amplifier.</li> </ul>	<div style="border: 1px solid black; padding: 5px; margin-bottom: 10px;"> <p style="text-align: center;">Standard Version</p>  </div> <div style="border: 1px solid black; padding: 5px;"> <p style="text-align: center;">My version with SeriesOne dual antenna receiver</p>  </div>







 <b>Selected Items</b>		
Price	Description	Picture
\$300	<b>50) Samson Wireless AG1</b> <ul style="list-style-type: none"> <li>• wireless guitar pickup</li> <li>• <a href="http://www.samsontech.com">www.samsontech.com</a></li> <li>• <a href="http://www.wholenote.com">www.wholenote.com</a></li> </ul>	
\$250	<b>50) Boss RV-5 Reverb Unit</b> <ul style="list-style-type: none"> <li>• <a href="http://www.SamAsh.com">www.SamAsh.com</a></li> <li>• Used primarily for vocal enhancement despite it being a guitar pedal</li> </ul>	
\$35	<b>60) Weltmeister Music Stand</b> <ul style="list-style-type: none"> <li>• <a href="http://www.MusiciansFriend.com">www.MusiciansFriend.com</a></li> </ul>	
\$40	<b>70) Konig &amp; Meyer Guitar Stand</b> <ul style="list-style-type: none"> <li>• <a href="http://www.wholenote.com">www.wholenote.com</a></li> </ul>	









## Considered Items

Not ultimately chosen but useful to see... could be good for others.







### Guitars

 <b>Considered Items</b>		
Price	Description	Picture
\$3000	<b>80) Les Paul Custom Wine</b> <ul style="list-style-type: none"> <li>• <a href="http://www.gibson.com">www.gibson.com</a></li> <li>• OK, this was never expected to be a travel guitar... but I did buy one while traveling and managed to get Les Paul, B.B. King, and Jim Marshall (of Marshall Amplifiers) to sign it. Go figure.</li> </ul>	
\$150	<b>90) Washburn Rover</b> <ul style="list-style-type: none"> <li>• <a href="http://www.SameDayMusic">www.SameDayMusic</a></li> <li>• built for the overhead in an airplane</li> <li>• good reviews</li> <li>• very affordable</li> <li>• <b>needs a separate pickup</b></li> </ul>	
\$1600	<b>90) KYDD carry-on stand-up bass</b> <ul style="list-style-type: none"> <li>• <a href="http://www.bananas.com">www.bananas.com</a></li> </ul>	
\$400	<b>90) Nomad portable guitar &amp; amp</b> <ul style="list-style-type: none"> <li>• build in amp</li> <li>• tinny sound</li> </ul>	







 <b>Considered Items</b>		
Price	Description	Picture
\$299	<b>90) Pignose acoustic with build-in amp</b> <ul style="list-style-type: none"> <li>• build in amp</li> <li>• called a "Smitty" or possibly from a partner company named "Smitty"</li> </ul>	
\$250	<b>90) Pignose electric with build-in amp</b> <ul style="list-style-type: none"> <li>• build in amp</li> </ul>	
\$350	<b>90) Baby Taylor</b> <ul style="list-style-type: none"> <li>• <a href="http://www.taylorguitars.com">www.taylorguitars.com</a></li> <li>• ¾ size</li> <li>• 33.75 inches total</li> </ul>	
\$500	<b>90) Chiquita</b> <ul style="list-style-type: none"> <li>• <a href="http://www.erlewineguitars.com">www.erlewineguitars.com</a></li> <li>• 512-302-1225</li> <li>• 28" total length</li> </ul>	
\$599	<b>90) Larivee Parlor</b> <ul style="list-style-type: none"> <li>• <a href="http://www.larrivee.com">www.larrivee.com</a></li> <li>• 36.25" total</li> </ul>	
\$180	<b>90) Martin Backpacker</b> <ul style="list-style-type: none"> <li>• nylon or steel strings</li> </ul>	

 <b>Considered Items</b>		
Price	Description	Picture
\$80	<b>90) Montana Backpack Guitar</b> <ul style="list-style-type: none"> <li>• <a href="http://www.WholeNote.com">www.WholeNote.com</a></li> <li>• 36" long</li> <li>• 2.5 lbs</li> <li>• with case</li> <li>• alternative</li> </ul>	
\$500	<b>90) Papoose</b> <ul style="list-style-type: none"> <li>• <a href="http://www.tacomaguitars.com">www.tacomaguitars.com</a></li> <li>• tuned to "A"</li> <li>• 33"</li> </ul>	
\$525	<b>90) Soloette</b> <ul style="list-style-type: none"> <li>• <a href="http://www.soloette.com">www.soloette.com</a></li> </ul>	
\$395	<b>90) Tommyhawk</b> <ul style="list-style-type: none"> <li>• 973-927-6711</li> </ul>	
\$500	<b>90) Traveller</b> <ul style="list-style-type: none"> <li>• <a href="http://www.travelguitar.com">www.travelguitar.com</a></li> </ul>	
\$395	<b>90) Vagabond</b> <ul style="list-style-type: none"> <li>• <a href="http://www.stringsmith.com">www.stringsmith.com</a></li> <li>• 33" total</li> <li>• \$175 for pickup/preamp</li> </ul>	
\$300	<b>90) Yamaha APXT1</b> <ul style="list-style-type: none"> <li>• Acoustic/Electric travel guitar</li> <li>• <a href="http://www.yamaha.com">www.yamaha.com</a></li> <li>• roughly 40"</li> </ul>	

## Amplifiers





 <b>Considered Items</b>		
Price	Description	Picture
\$500	<b>80) Peavey Escort 2000</b> <ul style="list-style-type: none"> <li>• <a href="http://www.peavey.com">www.peavey.com</a></li> <li>• Ultimately I didn't get this, but I've now spoken with several working musicians who all agree this is the best sounding and toughest of the all-in-one P.A. sets on the market.</li> <li>• you can pick them up on eBay fairly cheap</li> </ul>	
\$500	<b>80) Crate TX50DB</b> You see these (both standard and Limousine versions) in New York parks and subways a lot. They sound good, have decent battery life, and transport well.  They aren't as good a choice for airline travel however as they take up a lot of space just due to their shape. Tough to take both a guitar and an amp on board as carry-on unless there's a way to get them in to a single covered bag. <ul style="list-style-type: none"> <li>• <a href="http://www.crateamps.com">www.crateamps.com</a></li> <li>• <a href="http://www.guitarplaza.com">www.guitarplaza.com</a></li> <li>• <a href="http://www.music123.com">www.music123.com</a></li> <li>• <a href="http://www.musiciansfriend.com">www.musiciansfriend.com</a></li> <li>• <a href="http://www.samash.com">www.samash.com</a></li> </ul>	
\$150	<b>80) Roland MicroCube Amp</b> Relatively new on the market. Haven't tried one. But the general reviews are good. <ul style="list-style-type: none"> <li>• <a href="http://www.roland.com">www.roland.com</a></li> <li>• <a href="http://www.SameDayMusic.com">www.SameDayMusic.com</a></li> </ul> The only problem... only one input. The Fender amp can has two inputs.	
\$137	<b>80) AXL Thin Amp</b> Haven't tried this either. Could be great for hotel rooms and really small environments. <ul style="list-style-type: none"> <li>• <a href="http://www.Bananas.com">www.Bananas.com</a></li> </ul>	
\$200	<b>80) Alesis Roadfire</b> Haven't tried this. It's relatively new. Has a metal case however... likely to show wear quickly. Also, only one input. <ul style="list-style-type: none"> <li>• <a href="http://www.AmericanMusical.com">www.AmericanMusical.com</a></li> </ul>	



 <b>Considered Items</b>		
Price	Description	Picture
???	<b>80) Fliptone v.25 Amp</b> This is very cool. Flat panel technology. Would likely fit in a laptop bag alongside a laptop. Leaves the guitar case free to hold more stuff. No available price as of this writing. <ul style="list-style-type: none"> <li>• <a href="http://www.TravelerGuitar.com">www.TravelerGuitar.com</a></li> </ul>	
\$800	<b>95) AEG Compact 60 Amp</b> <ul style="list-style-type: none"> <li>• Expensive for a battery powered amp... but undoubtedly the very best sound for any portable battery powered unit on the market.</li> <li>• battery powered</li> <li>• 30.25"x13"x9",</li> <li>• 18.75 lbs package</li> <li>• 60-watt</li> </ul>	
\$100	<b>95) Pignose Hog 20 Amp</b> <ul style="list-style-type: none"> <li>• substantially better sound than the tiny original AA-powered Pignose</li> <li>• battery powered</li> <li>• 11" x 8" x 7"</li> <li>• <a href="http://www.MusiciansFriend.com">www.MusiciansFriend.com</a></li> </ul>	
\$140	<b>95) Pignose Hog 30 Amp</b> <ul style="list-style-type: none"> <li>• battery powered</li> <li>• decent sound</li> <li>• hard to find in stores</li> <li>• 13.5" x 9.5" x 17"</li> <li>• <a href="http://www.MusiciansFriend.com">www.MusiciansFriend.com</a></li> </ul>	
\$900	<b>90) Fender Passport 250 Deluxe</b> <ul style="list-style-type: none"> <li>• battery powered</li> <li>• comes in a smaller model with 3 inputs... don't get that one.</li> <li>• This one has four or more inputs, suitable for two guitars and two microphones</li> <li>• The sound on these needs much more shaping (care and attention to equalization) or it winds up sounding muffled at a short distance from the speakers. The Peavy 2000 system sounds better. Still... this is OK.</li> <li>• <a href="http://www.MusiciansFriend.com">www.MusiciansFriend.com</a></li> </ul>	

## Miscellaneous

 <b>Considered Items</b>		
Price	Description	Picture
\$250	<b>90) Heavy Duty dual guitar gig bag</b> <ul style="list-style-type: none"> <li><a href="http://www.StashCases.com">www.StashCases.com</a></li> </ul>	
\$180 to \$350	<b>10) Wheeled Duffel Bag</b> <p>Since the custom bag described earlier had some issues with airline size regulations (combined dimensions are greater than 62"), this duffel proved to be big enough for everything but the guitar which now simply goes as carry-on.</p> <p>I got an older model on a discount for about \$125. Turns out to be tough and big. Key elements are that it has lots of pockets, has wheels and a handle, has backpack straps, has enough hard shell to protect the Fender amp can, and it meets airline requirements.</p> <p>The problem... after 9-11 and after the various airline difficulties, weight restrictions limited baggage to 50lbs down from 70lbs. In the end I had to retire this bag in the interests of having fewer difficulties with the airlines.</p> <ul style="list-style-type: none"> <li><a href="http://www.HighSierraSport.com">www.HighSierraSport.com</a></li> <li>36" wheeled Duffel (model AT-102)</li> </ul>	
\$370	<b>40) Samson handheld XLR</b> <ul style="list-style-type: none"> <li><a href="http://www.samsontech.com">www.samsontech.com</a></li> <li>or <a href="http://www.wholenote.com">www.wholenote.com</a></li> <li>or <a href="http://www.ProAudioMusic.com">www.ProAudioMusic.com</a></li> <li>or <a href="http://www.bhphotovideo.com">www.bhphotovideo.com</a></li> <li>I didn't get this... but I might at some point just so I can stick a regular microphone into the loop.</li> </ul>	
\$50	<b>95) Axman Folding Music Stand</b> <ul style="list-style-type: none"> <li><a href="http://www.MusiciansFriend.com">www.MusiciansFriend.com</a></li> </ul>	

 <b>Considered Items</b>		
Price	Description	Picture
\$40	<b>95) Catch-o-matic guitar stand</b> <ul style="list-style-type: none"> <li>• <a href="http://www.wholenote.com">www.wholenote.com</a></li> </ul>	
\$600	<b>90) Battery powered mixer</b> <ul style="list-style-type: none"> <li>• battery powered</li> <li>• <a href="http://www.walker-labs.com">www.walker-labs.com</a></li> </ul>	
\$280	<b>90) Battery powered mixer</b> <ul style="list-style-type: none"> <li>• <a href="http://www.samsontech.com">www.samsontech.com</a></li> </ul>	
\$25	<b>90) Battery powered mixer</b> <ul style="list-style-type: none"> <li>• <a href="http://www.MusiciansFriend.com">www.MusiciansFriend.com</a></li> <li>• for plugging more inputs into the limited one or two inputs of a portable amp</li> <li>• passive mixer</li> </ul>	

## Contact Information

If you'd like more information feel free to snail-mail or email me at:

**Allan Barnard**  
 2201 S. Lakeline Blvd.  
 Apt. #2208  
 Cedar Park, TX  
 78613

646-258-1858 (cell)  
[Allan.Barnard@CheshireTechnology.com](mailto:Allan.Barnard@CheshireTechnology.com)  
[Allan@ParkJammer.com](mailto:Allan@ParkJammer.com)  
[www.ParkJammer.com](http://www.ParkJammer.com)